

Installation Instructions

For set # 3.4147
1973-1980 Chevrolet Suburban
Body Mounts (2WD and 4WD)



1131 VIA CALLEJON, SAN CLEMENTE, CA

© 2011 Energy Suspension. All rights reserved.
May not be reproduced, in any form, or by any means,
without the written consent of Energy Suspension.

It is recommended that if you are unfamiliar with this type of work that you refer to a qualified service center specializing in this type of work. It is also recommended that if you choose to do this work yourself that a factory service manual be obtained for the proper procedures pertaining to removal, replacement and proper torque specifications for your vehicle. This instruction sheet is intended as a guideline for the safe installation of Energy Suspension's polyurethane bushings, once you have removed the factory suspension components from your vehicle. Wheel alignment is almost always disturbed when suspension components are removed or replaced. It is recommended that you have the alignment checked on your vehicle at a qualified alignment shop.

Parts List

2 ea 4010 (1.100" Flange Size)
2 ea 4011 (1.275" Over All Length)
6 ea 4026 (0.750" Flange Size)
6 ea 4059 (0.435" Flange Size)
2 ea 4114 (0.775" Over All Length)

2 ea 4115 (0.835" Flange Size)
4 ea 4135 (1.290" Flange Size)
12ea 15.03.05.39 (2" OD x 1/2" ID Washer)
1 ea 17313 (Instructions)

Spray all nuts to be removed generously with your favorite rust buster.

Note: When disassembling, note the quantity and positions of any shims that may have been inserted for body alignment. These shims **MUST** be reused to ensure proper body alignment.

CAUTION! Only raise body high enough to remove & replace mounts. Always watch the fan shroud for sufficient clearance when raising the body. When jacking the body use a long enough 2X4 or 4X4 for maximum support. Never put jack directly on body panels.

Install mounts one side at a time with bolts on other side loosened only.

Re-torque all bolts to factory specifications.

POSITION # 1

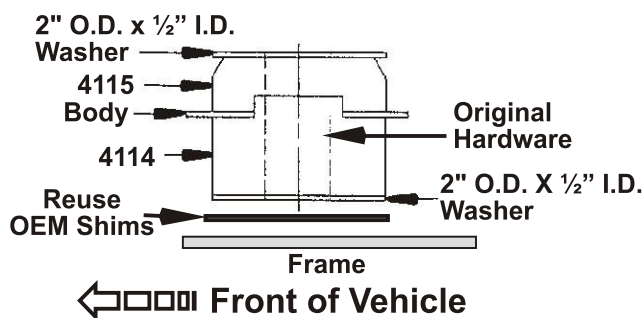

Must re-use original hardware.

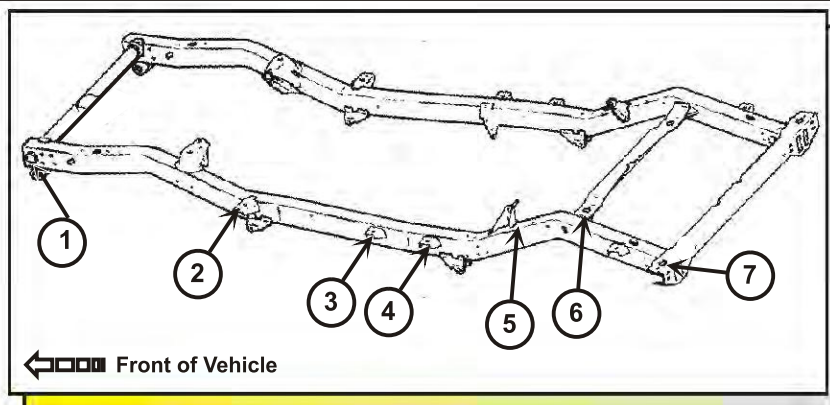

POSITION # 2

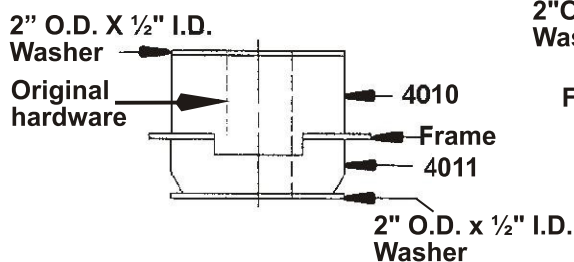

POSITIONS # 3, 5, 7

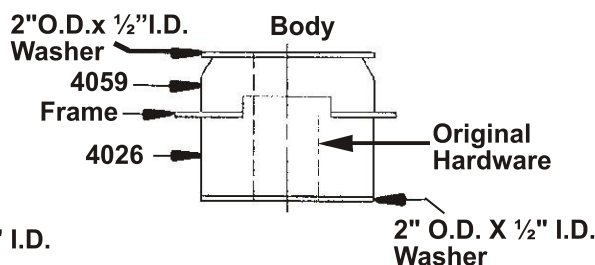

POSITIONS # 4, 6

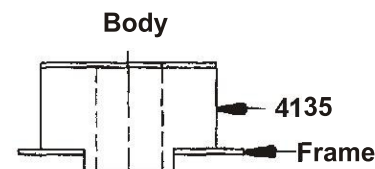

17313

6/APR/11 MAM