

Installation Instructions

For Set # 3.4174

67-68 CHEVROLET C-10 PICKUP

Body Mount Set

© 2021 Energy Suspension. All rights reserved.
May not be reproduced, in any form, or by any means,
without the written consent of Energy Suspension.

It is recommended that you refer to a qualified service center if you are unfamiliar with vehicle chassis and suspension repair work. This instruction is intended as a guideline for the safe installation of Energy Suspension polyurethane bushings after original equipment has been removed from the vehicle. Reference the vehicle manufacturer's service manual for component removal and replacement procedures and torque specifications. Before beginning work, read installation instructions and verify parts received match P/N's and quantities in the parts list. In the case of a discrepancy, contact Energy Suspension Customer Service (949-361-3935). Energy Suspension parts are designed to work with vehicles in a good state of repair. We cannot be held responsible for suspension or steering related problems occurring due to poor vehicle maintenance. Wheel alignment is altered when suspension components are removed and replaced. It is highly recommended that your vehicle is checked and adjusted by a qualified alignment shop prior to use.

NOTE: When disassembling the body mounts, be sure to note the number and position of shims that may have been used to align the body. These shims will have to be reused to retain proper body alignment.

RUST: Older Vehicles have rust. The amount of rust will depend on the location and condition of the vehicle being worked on. This kit includes hardware like nuts, bolts and washers but it does not include the captured nuts inside the body that are inaccessible from the outside. If any of the bolts snap off or strip out the threads during removal you may have to cut open the body panel to remove and replace the captured nut. Also, the frame and frame perches have been known to rust out to the same diameter as the old rubber body mount or the metal ring inside the original rubber body mount will rust and stick to the frame perch making the hole seem smaller. In these cases the frame perch will need to be replaced or the rusty metal ring will need to be removed.

CAUTION: Remove all the body mount bolts on one side of the vehicle. Loosen but do not remove all the body mount bolts on the opposite side of the vehicle. Remove the front bumper. Remove grounding strap at Pos. 1 passenger side. Only raise one side of the vehicle at a time, lifting the body only high enough to remove/replace the mounts. Always watch the fan shroud and remove the fan or fan shroud if additional clearance is needed. Observe the brake lines, shift linkage, steering shaft to steering gear box and various hoses for sufficient clearance when raising the body. Check the motor mounts. Defective motor mounts may cause the fan to hit the fan shroud. When jacking the body, use a 2x4 or equivalent to spread the weight. **Never** place jack faces directly on body panels! When all mounts and hardware are installed, torque all bolts to factory specifications. Replace all items removed in previous steps. Recheck all nuts and bolts before driving and visually inspect and re torque all fasteners after 200, 500 & 1000 miles. Recheck fasteners during routine vehicle service.

Parts list: 3.4174

- 2 - **04P04400** (Lower mount Position 1)
- 2 - **04P04404** (Upper mount Position 2)
- 2 - **04P04405** (Lower mount Position 2)
- 4 - **04P04435** (Upper & Lower mount core support)
- 2 - **04P04440** (Upper mount Position 1)
- 2 - **15.03.05.39** (2" x 1/2" x 1/8" Flat washer Core Position Upper)
- 2 - **15.03.09.39** (2" x 7/16" x 1/8" Flat washer Position 2 Lower)
- 2 - **15.03.16.39** (2-1/2" x 9/16" x 1/8" Flat washer Position 1 Lower)
- 8 - **15.03.36.39** (1-3/4" x 1/2" x 1/8" Flat washer Core Position)
- 4 - **15.03.83.39** (1-1/16" x 1/2" x 1/8" Flat washer Core Position Top & Bottom)
- 4 - **15.03.138.39** (3-1/2" x 9/16" x 1/8" Flat washer Position 1 & 2 Upper)
- 4 - **15P0314942** (1" x .465" x 1/8" Flat washer Position 2 Top & Bottom)
- 4 - **15P0316939** (1-3/16" x 9/16" x 3/16" Flat washer Position 1 Top & Bottom)
- 2 - **15.05.46.39** (1/2-13 x 3" Bolt Core Position)
- 2 - **15P0512940** (7/16-14" x 6" Bolt Position 2)
- 2 - **15P0514140** (9/16-12" x 6" Bolt Position 1)
- 2 - **15.07.03.40** (1/2-13" Nylock nut Core Position)
- 2 - **15.07.05.40** (9/16-12" Nylock nut Position 1)
- 2 - **15.10.15.39** (.875" x .687" x 2.300" Sleeve Position 2)
- 2 - **15.10.62.39** (.875" x .687" x 2.200" Sleeve Position. 1)
- 1 - **17P17703** (this instruction sheet)

Mount Position Diagram

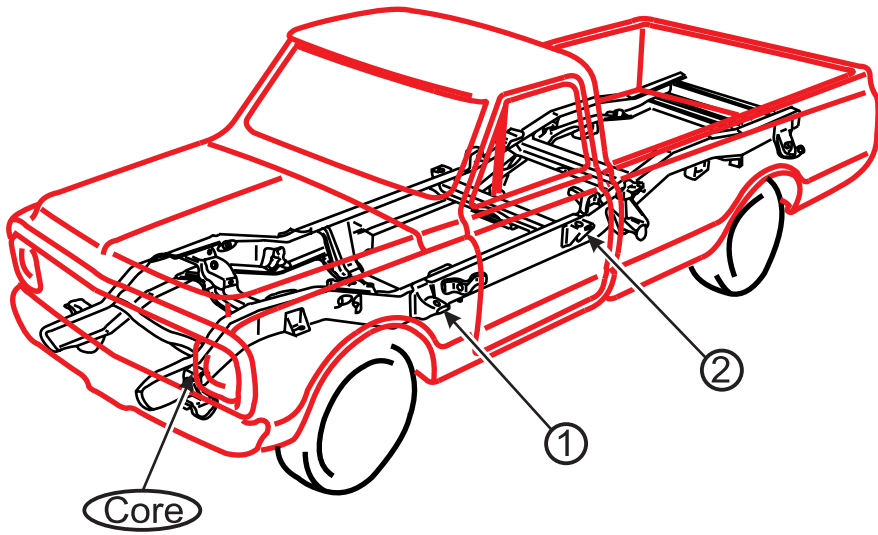

CORE POS.

With $\varnothing 1-5/32''$
in frame perch

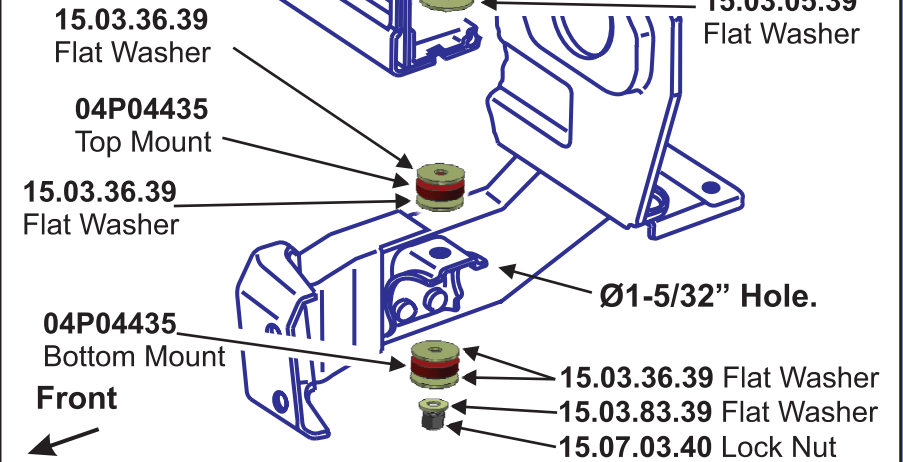

POS. 1

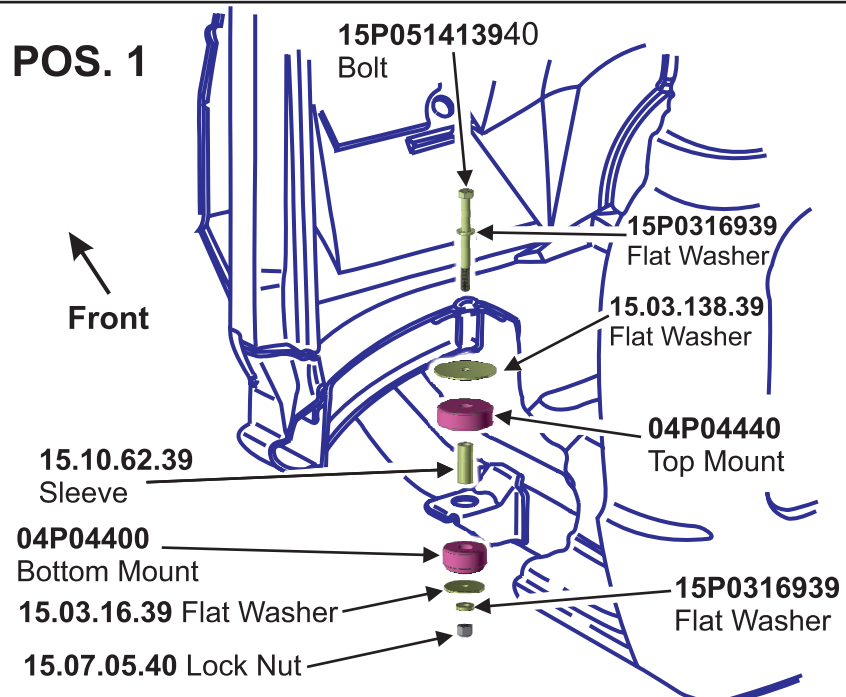

POS. 2

